

FAIRBANKS[®]

S C A L E S



LSA SERIES

LIVESTOCK SCALE - SINGLE ANIMAL

The LSA Series is a rugged, legal-for-trade weighing enclosure with multiple gate configuration options for single animal weighing.

LSA SERIES

LIVESTOCK SCALE - SINGLE ANIMAL

Weighing Solutions for the World Since 1830

RELIABLE WEIGHING FOR LIVESTOCK OPERATIONS

Fairbanks legal for trade LSA Series Scale provides a dependable means to safely weigh all types of livestock. Boasting a 5,000 lb capacity, the LSA is ideal for weighing single cows, horses, sheep, goats, hogs and exotics. Due to its size and versatility, the LSA is perfect for use in small farm operations as well as animal clinics, training centers, schools and local animal science organizations.

RUGGED KICK PANEL AND RACK DESIGN

Because livestock are known to jump and kick when being corralled, the LMA utilizes 48" tall kick panels on all sides of the scale to combat routine wear and tear and reduce the possibility of animal injury. The solid steel panels also shield outside movement from the animals' line of sight, which helps keep them calm during the weighing process. The kick plates are attached to the scale's bolt-on racks and self-latching swing gates, which are made of 2" and 3" steel tubing for longevity.



Spring-loaded Latch Assembly
A heavy-duty, spring-loaded latch assembly secures the weighing enclosure after livestock are loaded.

SAFE, ANTI-SLIP FLOORING

The LSA deck features X-Lug flooring, today's most advanced animal safety system. Made from recycled rubber and plastics, X-Lug prevents harmful hoof slipping and, unlike wood, will not rot or harbor bacterial growth.



X-Lug Scale Deck Flooring

INSTRUMENT OPTIONS

The LSA Series offers instrumentation options designed to fit every type of application, from basic "weigh only" needs, to rate of gain tracking, ID, shrink and more.



FB2255
Basic Weighing



FB500
Intermediate Weighing



FB700 WeighCenter
Advanced Weighing



Head gate configuration

SPECIFICATIONS

- Capacity 5,000 lbs
- Dimensions
 - Outside 9 ft 1 in x 3 ft 11 in x 8 ft 2 in
 - Inside 8 ft 2 in x 2 ft 10 in x 8 ft 2 in
- Weighbridge construction . . . Steel, covered with X-Lug anti-slip flooring
- Finish Beige, powder coat paint
- Load cell Nickel-plated S-Beam, four per scale
- Minimum graduation 1 lb
- Overload protection 150% of capacity
- Operating temperature 14° F to 104° F, -10° C to +40° C
- Shipping weight 2,2700 to 2,300 lbs
- Approvals NTEP CC# 19-095

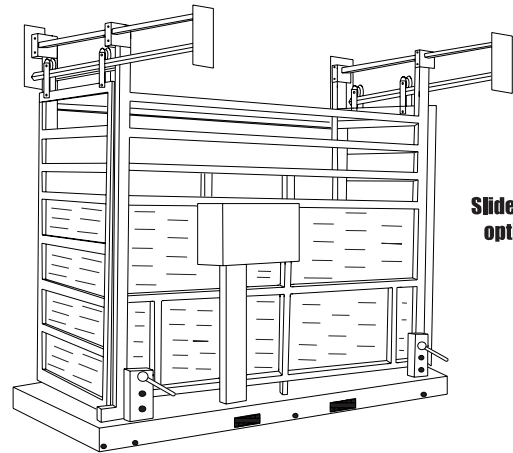

Slide gate option*

*Substitute a head gate or combine a swing and slide gate to meet application requirements.

OPTIONS

- FB2255 Instrument
- FB500 Instrument
- Protective enclosure
- FB700 WeighCenter
- Pedestal
- Ticket printer
- Remote display
- Rate of Gain software
- Gate configurations (swing, slide, head or combination)

Your Fairbanks Scales Authorized Representative is:

Call toll-free for the representative nearest you:

(800) 451-4107

Call between 8:00 a.m. – 5:00 p.m. Central Time

Corporate Headquarters: 6800 W. 64th Street, Overland Park, Kansas 66202
(816) 471-0231 Internet Address: <http://www.Fairbanks.com>



NTEP approved for commercial applications.

